



# COMMUNIQUE #47

## STARDATE 2009.11

### NEW IN THIS ISSUE

We have included several new items in this issue.  
New Ship Card: Lyran War Cruiser Scout (BoM)  
Revised Ship Card: WYN Auxiliary Cruiser  
Borders of Madness Ship Card: Hydran New Scout  
Large Format Ship Card: Klingon C10 Heavy Dreadnought  
New scenario: 8CM35: Battle Without Hope

### RELEASED IN 2009

Just released was *Hydran Attack* with more ships for the Hydrans, Lyrans, Klingons, Kzintis, and WYNs. The ships included are: Hydran Ranger, Iroquois, Tartar, Rhino Hunter, Buffalo Hunter, Lancer, Hunter, and Pegasus; Lyran Light Cruiser, New Heavy Cruiser, War Destroyer; WYN FF and AuxC; Klingon F5W; and Kzinti FFK. Six more ships are in the boosters.

*Squadron Boxes #25 and #26*, and *Border Box #9*, will follow. *Squadron Box #27* will appear early next year.

We have released *Federation Commander: Booster Pack #91*, *The Franz Joseph Ships* (including the classic DN, CA, DD, SC, and Tug, along with the DDM, DDL, and DDG) and *Squadron Box #91* containing new production of the classic "Zocchi Plastics". These are in the classic white plastic.

*Border Box #8* was released on 23 February (4408, \$99.95).

*Federation Commander: Briefing #2* has been released and covers "The Middle Years" (4022, \$19.95).

The *Reference Rulebook* has been released and includes all of the *rules* from all products and all updates (4020, \$14.95).

### SCHEDULED FOR 2010

The Big Release will be *WAR AND PEACE*, to be released at Origins with ISC, Vudar, and Andromedan ships.

*Briefing #3* will have "support units" and *Federation Admiral* will be the new campaign system for *Federation Commander*.

We will see a new series of independent *Booster Packs*. *Federation Commander: Booster Pack #92* will contain ships that were seen in *Briefing #1*. *Booster Pack #93* will contain ships seen in *Captain's Log*. *Booster Pack #94* will have light tactical transports. *Booster Pack #95* will have tugs, and *Booster Pack #96* will have more freighters and transports.

*Borders of Madness #1* will appear next year with over 70 ships never intended for *Federation Commander*, possibly including scouts, carriers, and maulers.

### PUBLISHER'S INFORMATION

*FEDERATION COMMANDER: COMMUNIQUE #47* is published and copyright © 2009 by Amarillo Design Bureau, Inc., [www.StarFleetGames.com](http://www.StarFleetGames.com), PO Box 8759, Amarillo TX 79114.

Elements of the *Star Fleet Universe* are the property of Paramount Pictures Corporation and are used with their permission.

### FEDERATION COMMANDER Organized League Play

The on-line forms for registering your store as a site for Organized League Play are in the *Commander's Circle*. Also available is the form to register your completed games, and you can even use the same form to register future games as a means of inviting people to attend and join the fun.

You will find a link to the *Commander's Circle* at:

[www.StarFleetGames.com/fccc/login.php](http://www.StarFleetGames.com/fccc/login.php)

along with everything else for this game system.

Many stores have already signed up, and prizes (a series of "bonus cards" used to give ships a special ability) are being mailed out to those stores. The scenarios of the last six months of 2009 are as follows and reflect the period of tension before the General War. Get these reports to us ASAP!

July: 8B101 Sabotage!

August: 8B103 The Coming of the Meteor

September: 8B108 Landing Party

October: 8B111 Pandora's Box

November: 8B113 The Critical Hit

December: 8B115 Passing Engagement

In 2006, the Federation *barely* stopped the Klingons. The Romulans did not do that well in 2007. During 2008, the Tholians repulsed a Klingon invasion and the Klingon-Lyran Coalition conquered the Hydrans. Earlier this year, the Pirates rocked!

### COMMANDER NEWS

#### THE BBS & FORUM: KEYS TO COMMUNICATION

The BBS ([www.StarFleetGames.com/discus](http://www.StarFleetGames.com/discus)) can be confusing at first sight, as it has hundreds of topics, used daily by a thousand players. Registration is free, but we do require all participants to use their real names. (This not only improves the overall tone of civility, but makes sure you get credit for any suggestions you make.) When you register, you will see topics for each of our product lines. Feel free to venture into the broader universe as you get more comfortable with the system.

There is also a forum (much easier for new players) on the [www.FederationCommander.com](http://www.FederationCommander.com) website. It allows screen names and avatars but isn't used for submissions of new items.

Several versions of the updated Master Ship Chart for *Federation Commander* are on the *Commander's Circle*.

The *CRUL (Consolidated Rules Update List)*, listing all rules changes, is now in the *Commander's Circle*.

In the *Commander's Circle* is the Scenario Designer's Guide: <http://www.StarFleetGames.com/fc/designguide.shtml>.

## WHAT SHIPS DO YOU WANT?

Here is your chance to get what you want. Whether you are a veteran player of *Star Fleet Battles* and familiar with the thousands of starships in that game system, or a new player of *Federation Commander* and just have a vague feeling that some ship of some kind is missing from your fleet, tell us what you want and we'll consider adding it via *Communique* or in a future expansion. Here are some player suggestions for this year and next:

Generic units: small planetary ground bases £, ship-yard construction dock £.

Police ships: Romulan Snipe-P £, Kzinti police frigate†, Tholian POL†.

Federation DDF fast destroyer¥.

Klingon F5D drone-armed frigate variant, F6B variant, D6J penal ship.

Romulan SpH-J¥, K10R, KillerHawk¥, K7R¥, JayHawk, Vulture¥, KD5R¥.

Kzinti destroyer.

Gorn dreadnought-cruiser¥, HDE, MCC¥.

Hydran D7H *Anarchist* (captured Klingon D7).

Andromedan (scheduled for *War & Peace*).

Lyrans police cutter POL £.

Seltorian Hive Ship (larger than the Battlewagon).

Borders of Madness: maulers, scouts, survey ships.

All empires: commando ships £.

¥ Possible inclusion in *FC: Gorn Attack* in 2011.

† Was in *FC: Briefing #2*

£ Scheduled for *FC: Briefing #3 Support Units*.

## FED COMMANDER: TO DATE

*LINE OF BATTLE* (\$19.95, Stock #4007) has extra battleship cards for larger battles.

*Federation Commander: Briefing #1* (\$12.95, Stock #4021) was released in 2008. This includes 24 scenarios, plus tactics, six new ships, and a Scenario Designer's Guide.

*Squadron Boxes #22* (\$34.95, Stock #4322), *#23* (\$34.95, Stock #4323), and *#24* (\$34.95, Stock #4324) were released in 2009.

We released *Klingon Space* (\$34.95, Stock #4008) for those who bought *Romulan Border* first.

*Captain's Log #37* (\$18.95, Stock #5737), *Captain's Log #38* (\$19.95, Stock #5738), and *Captain's Log #39* (\$19.95, Stock #5739) each have a dozen pages of new ships, scenarios, and tactics for *Federation Commander*.

Already released: *Klingon Border*, *Klingon Attack*, *Romulan Border*, *Romulan Attack*, *Tholian Attack*, *Battleships Attack*, *Distant Kingdoms*, *Orion Attack*, *Hydran Attack*, *Booster Packs #0-#27* and *#91*, *Squadron Boxes #0-#24* and *#91*, *Border Boxes #1-#8*, *Captain's Log #32-#39*, *Academy*, *Graduation*, *Romulan Space*, *Klingon Space*.

## UNIVERSE NEWS

*Federation Commander* is only one of the games in the *Star Fleet Universe*. All of our games use a common historical background and technological database.

There are three kinds of *Federation Commander* players: new players who have never played *Star Fleet Battles*, veterans of *SFB* who haven't played in years but are now playing *FC*, and active *SFB* players who have decided to also play *FC*. Members of any group could have played our other games. This part of *Communique* will have news on our other games. Our opt-in Email newsletter goes to fans of all our games; each issue includes links to information for each game.

The new *Starmada* and *Klingon Armada* books were released in September 09.

*Federation & Empire* is out of stock until the new edition. Its next major expansion, *ISC War*, will follow.

*Star Fleet Battles* received *Module X1R X-Ship Reinforcements* at Origins 2008, *Module Y2* in October 08, *G3* in February 09, and *G3A* in August 09.

*Prime Directive d20 Modern* has been released and *Klingons d20 Modern* was released on 19 Oct 09.

*Prime Directive Federation* is in final development.

*Prime Directive Tholians* is in development for 2010.

We are working on conversions of *Prime Directive* to other systems including D6, Fudge, SW, and HERO.

## WEBSITE UPDATE

We have completed the project to merge our two websites. The "new" [www.FederationCommander.com](http://www.FederationCommander.com) is now nested inside the "original" site which you all know is [www.StarFleetGames.com](http://www.StarFleetGames.com). Why did we do this?

We originally made [FederationCommander.com](http://FederationCommander.com) a separate site because we feared new players would find the original [StarFleetGames.com](http://StarFleetGames.com) site too huge and too confusing. As time went by, users of the "new" site wanted more and more of the "original" site's information copied over, and improvements to the "original" site had made it vastly easier to use. (The new site index makes it possible to find anything you want, quickly and easily.) There just was no reason to maintain two increasingly identical sites. Players were actually getting confused as to which site they were on at any given moment because the two sites were so extensively cross-linked and had so many identical pages.

Let us know (at [graphics@StarFleetGames.com](mailto:graphics@StarFleetGames.com)) if you see any glitches in the website, or think of ways to improve the website for all of us.

The website:

[www.StarFleetGames.com](http://www.StarFleetGames.com)

includes a wealth of information, downloads, and other items for players of all of our games. Explore, look around, click on random entries in the *Master Index*, and you may be surprised what you find.

## FEDERATION COMMANDER SCENARIO

### (8CM35) BATTLE WITHOUT HOPE

All empires operate networks of subspace communications stations to carry military and civilian data. All empires detect and identify the communications stations of other empires, and plan to eliminate them in wartime. All empires built additional secret communications bases which are not activated until wartime, so they cannot be detected years in advance, and are not subject to detailed pre-war plans for their destruction.

During the collapse of the Hydran defenses in the early part of the General War, one of these secret bases began transmitting high-powered signals in a new code that the Klingons could not break.

#### (8CM35a) NUMBER OF PLAYERS

**Two:** The Klingon player and the Hydran player.

#### (8CM35b) INITIAL SETUP

**Map:** Set up the map with 3 panels across and 2 panels high if using small hexes (4 wide and 3 high if using large hexes). Place a planet in the lower left corner. This is a “location” map. Any unit which ends the turn more than 25 hexes from the planet has disengaged and has left the scenario. Klingon units may only disengage in directions A, B, or C. Hydran units may not disengage. Units which disengage in an unauthorized direction are considered destroyed.

**Hydran Forces:** Set up first within eight hexes of the planet: Ranger, Lancer, Knight, Cuirassier, Hunter, each with the full load of Stinger fighters. The fighters may be launched and placed within two hexes of their parent ship before the scenario begins.

**Klingon Forces:** One Klingon F5 placed 25 hexes in direction B from the planet. See (8CM35d2).

#### (8CM35c) OBJECTIVE

**Mission-Klingon:** Destroy the Hydran communication stations. This is worth 100 points (50 in Fleet Scale).

**Mission-Hydran:** Destroy or cripple as many Klingon ships as possible.

**Time Limit:** The scenario continues until all Hydran units are destroyed or captured.

**Victory:** Use the Point Value Victory System (8B2). The Hydrans get no points for “damaging” Klingon ships, only for destroying or crippling them. Captured Klingon ships count as destroyed ships for this purpose.

#### (8CM35d) SPECIAL RULES

**1. Planet:** There are six communication stations, one per hex side. The communications stations are built deep inside the living rock of the planet and are hard to destroy. Deduct three damage points from the damage

caused by each weapon within each volley. Each communications station is destroyed by 50 damage points (25 in Fleet Scale).

**2. Klingon Reinforcements:** At the start of each turn, roll one die, take the indicated Klingon ship, and place it 25 hexes from the planet.

1 = D7                      2 = D6                      3 = D5  
4 = F5                      5 = E4                      6 = Special

The first time a six is rolled, the Klingons receive a D7C. The second time, they receive a C8 dreadnought. Thereafter, they receive an F5 frigate.

#### (8CM35e) FORCE DYNAMICS

**1. Alternative Empires:** You can replace the Hydran ships with equivalent Kzinti, Federation, or Tholian ships.

**2. Balance:** You can adjust the balance of the scenario by changing the Klingon F5 to an E4 or a D5.

#### (8CM35f) DESIGNER'S NOTES

The commo station is a dummy, transmitting gibberish. The Hydran plan is to delay the Klingon assault on their homeworld by luring them into a useless battle.

## INDEX FOR 2009:

- **Communique #37:** Scenario 8CM26 A Plague on Their Houses. Romulan War Eagle, ISC Frigate, Federation DDM, Lyran Hellcat BCH.
  - **Communique #38:** Scenario 8CM27 First and Future Shock. Revised Federation NCL. New ISC CC and Federation Tug. Larger Orion BCH.
  - **Communique #39:** Scenario 8CM28 What Price Victory? Revised Armed Cutter (#45), new Klingon G2, special Kzinti CVS, and larger Hydran Overlord.
  - **Communique #40:** New Orion Medium Raider, Revised Large Freighter, large format Neo-Tholian Heavy Dreadnought, Romulan Sparrowhawk-C Scout, Nebula rules, Pulsar rules.
  - **Communique #41:** Ships for the Middle Years (Kzinti DN, Fed CA, Klingon D7, Romulan WE), Scenario 8CM29 The Greening of Lot 49. Rules updates.
  - **Communique #42:** Ships for the Middle Years (Hydran Ranger, Lyran Tiger, Gorn Allosaurus), large format Orion Heavy Battlecruiser, Scenario 8CM30 The *Dakota* Incident. Rules update.
  - **Communique #43:** Ships from *Briefing #2* usable in any years (Federation Hospital Ship, Light Monitor), Revised WYN War Cruiser, Large Format Hydran Regent Light Dreadnought. Scenario 8CM31 The *Navajo* Incident.
  - **Communique #44:** Revised Seltorian CA, new Klingon Tug, early years Hydran CC, large format Lyran DNL, scenario 8CM32 Rescue the Supply Tug.
  - **Communique #45:** Revised WYN DW, new Romulan KD5R, Klingon D7E Survey Ship, large format Hydran DNL, scenario 8CM33 A Matter of Jurisdiction.
  - **Communique #46:** Revised Seltorian Destroyer, new Kzinti Drone Frigate, Klingon D5G Commando Ship, large format Federation BCP, scenario 8CM34 Groundfire.
- Index for 2006 was in *Communique #14 & Briefing #1*  
Index for 2007 was in *Communique #24 & Briefing #1*.  
Index for 2008 was in *Communique #36*.

## Rules & Rulings

Mike West reports: This issue, I will focus on the "scout" rules. As you know, scouts are a major part of *SFB*, which has no end of rules for jamming, counter-jamming, tactical intelligence, blinding enemy drones, and so forth. (Even *F&E* and the *SFBF* card game have rules for scouts and electronic warfare.) ADB, Inc., has previously published such rules for *FC* (in *Captain's Log #35* and in *Communique #28*) and just recently, ADB, Inc., did an entirely new set of them in *Hydran Attack*.

Those new rules were intended only for the Federation "Franz Joseph" Scout, which was published in *Booster #91* and became the first, and so far only, Ship Card in the game system to have "special sensors." This is an artifact of the various ancient contracts and licenses; ADB, Inc., more or less had to include the scout in *Squadron Box #91*, which forced it into *Booster Pack #91*, which forced a limited set of scout rules into *Hydran Attack*.

The new rules in *FCHA* are somewhat cleaner, faster, and simpler than those published before, and players have quickly taken a liking to them. In order to make them fully functional, we need to provide some additional information, as follows:

**(5S5) DESTRUCTION:** Special sensors are disabled on "torpedo" damage points.

**(5S6) BLINDING:** If a scout ship fires or launches any weapon other than a drone, anti-drone, or phaser-3, the act of such firing "blinds" one sensor, i.e., makes that sensor unable to function. Mark one sensor "used" for each such weapon fired/launched. (This may be a sensor you have already used that turn.) The "blinding" is removed at the end of the Turn. The second shot from a phaser-G in a given impulse blinds a sensor.

**(5S7) BASES:** In game systems that use special sensors and electronic warfare, these are key elements of bases. Bases can fire/launch weapons without blinding their sensors. Add sensors to bases (they don't replace anything, they are additions) as follows: starbase 8, battlestation 4, base station or mobile base 2, commercial platform 0. Use half of those numbers for Fleet Scale, i.e., a Fleet Scale starbase has four special sensors, and a Fleet Scale battlestation has two.

## New Miniatures

Released on 19 October 2009:

Shuttlecraft, Stock #0061, pack of 12, \$17.95

Hydran Fighters, Stock #0069, pack of 12, \$17.95

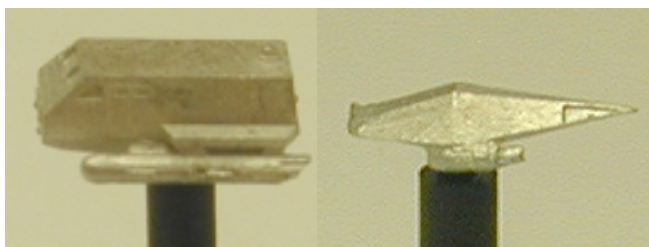

## Now In Your Store!



Fifteen new ships, plus the Energy Monster. New terrain rules for nebulae, black holes, and pulsars. Counters for the ships in *Booster Packs #91-#95*. Prototype rules for tugs and transports with cargo pods, scouts, and escorts. Eight scenarios, 140 1/2" and 80 1" counters.

Stock #4107, Retail price \$29.95.

## ADDED TO COMMANDER'S CIRCLE

From *Communique #40*: Large Freighter, Orion Medium Raider, Romulan SparrowHawk Scout, large format Neo-Tholian Heavy Dreadnought. (We post the separate ships six months after the issue.)

## NEWSLETTER

Check the website for news about the free on-line newsletter. It's full of fun and cool stuff.

[StarFleetGames.com/newsletter.shtml](http://StarFleetGames.com/newsletter.shtml)

## TACTICS WANTED!

Write up your favorite tactic (or dirty trick) and send it to us. A panel of expert players will judge these tactics for legality, creativity, and utility in combat, and we will print the ones with the highest scores in *Captain's Log*.

# CUSTOMER SUPPORT

We do as much as we can to help our customers enjoy our products, and are always seeking new ways and open to new ideas to do so. Here is a general summary of the kind of things we can do. (Sorry for the small type, it does show just how much customer support stuff we have!)

## Just Ask Us

You can contact the game designer at:  
[design@StarFleetGames.com](mailto:design@StarFleetGames.com)

You can contact our customer support person at:  
[support@StarFleetGames.com](mailto:support@StarFleetGames.com)

You can contact our sales department at:  
[sales@StarFleetGames.com](mailto:sales@StarFleetGames.com)

Try asking a question, and we'll answer as best we can. For that matter, you can always just call the office at 806-351-1950 during business hours (9-6 Central Time, M-F), and tell whoever answers (we take turns) what you need, and you will be sent to the right person to get your answer.

## Websites

Our site at [www.FederationCommander.com](http://www.FederationCommander.com) has a lot of stuff for you to use, and the *Commander's Circle* (found at <http://www.starfleetgames.com/federation/Commanders%20Circle/index.shtml>)

has lots of free downloads and other things. You can even download a demo copy of the game to give a friend.

The *StarBlog* on FederationCommander.com includes daily posts of what's going on, and the Forum on that site provides access to the *Federation Commander* community of players and to the game designers and customer support people.

## Need an Opponent?

There are a lot of ways to find one. Post a note in your game store. Go to the FederationCommander.com Forum and post a note in the *Local Groups & Retailers* section. Attend a local convention (if there is one). Go to the *Commander's Circle* and look at the player database (and post your information there so that the next person to check the list can find you).

Go to our primary BBS at [www.StarFleetGames.com/discus](http://www.StarFleetGames.com/discus) and look for the *Seeking Opponents* section and post a note there.

Go to [www.StarFleetGames.com/sitemap.html](http://www.StarFleetGames.com/sitemap.html) and look for the red **Find Opponents** button. Enter your data and in a few days you'll get an Email from our Customer Support Director with a list of gamers near you.

## Federation Commander Play-by-Email

Playing *Federation Commander* by Email is an alternative to playing Face-to-Face. While there are a few differences (i.e., your opponent isn't sitting across the table from you), it is the same game.

The basic gist of the *Federation Commander* Play-by-Email (PBEM) system is that you and your opponent submit your orders for the turn to a moderator via Email. The moderator then processes them, and sends a "SitRep" (Situation Report) to the players via Email. You receive the results, write up your next set of orders, and then submit your orders once again. The process is repeated until the game is completed. Sounds simple? That's because it IS! It'll take a little getting used to (after all, what doesn't?), but once you've got the hang of it, you'll be lobbing photon torpedoes (or whatever your weapon of choice is) at opponents from all over the world.

Every *Federation Commander* PBEM game has at least three participants: two or more players and one moderator. The moderator's purpose is to accept orders from the players

and carry them out, reporting the results of those orders to all players. While he is not a player, the moderator fulfills a very important role in the game. Good moderators and good players make for a good, enjoyable game of *Federation Commander*. Moderating a *Federation Commander* PBEM game is also an excellent way to learn more about the *Federation Commander* rules.

While there are some disadvantages to PBEM (it does take longer to finish a game), there are advantages as well. You can play against people in other parts of the world (how often do you get to Australia, anyway?), you can play multiple games at once, and you can have large multi-player games (without worrying about running out of chips and soda).

For more information about playing *Federation Commander* PBEM, please visit the Play-by-Email section at [www.StarFleetGames.com/pbemgames](http://www.StarFleetGames.com/pbemgames) soon, or check the PBEM section of either the Forum or the BBS.

## Federation Commander On-Line Gaming

Many people do not know that you can play *Federation Commander* on-line in real time against live opponents, any time you want, 24 hours a day.

A decade ago, [www.SFBonline.com](http://www.SFBonline.com) was created to provide players of *Star Fleet Battles* with an on-line gaming experience. It was a smash hit as hundreds of gamers joined the battles. Tournaments and other competitions, plus general open gaming, have gone on around-the-clock since then. This successful operation has been expanded to include *Federation Commander*! Now you can play with real live human opponents all over the world in real time 24 hours a day, seven days a week! The computer automates many functions and acts as a friendly assistant for mundane chores.

For a modest subscription fee of less than \$6 a month, you have access to all of the ships in the *Federation Commander* game system as well as new ships still in playtest and development. The Java Runtime system is compatible with Windows, Macintosh, and other systems.

Never worry about a lack of opponents. Never worry about opponents who don't show up for game day because of silly reasons like family reunions or their own weddings. Don't be cut off from your regular gaming group while on vacations or business trips.

Even better, you can join in on-line tournaments and campaigns, and your victories will add up to a higher and higher average score!

The system also allows you to chat with friends, taunt your enemies, and watch other players fight their own savage battles. (Why learn from your own mistakes when you can learn from someone else's?) This "observer" system allows players of either game (or those who have yet to join either) to learn the ins and outs of the other game before deciding to invest time and money in it.

So come to [www.SFBonline.com](http://www.SFBonline.com) right away. You can even fly the Federation CA or Klingon D7 as a free trial, or watch any game in play. Legendary *SFB* aces and new *Federation Commander* aces strut their stuff in combat arenas all the time, and you can learn from the best.

## On-Line Opt-In Newsletter

We publish a newsletter covering all of our products with information about the games. It's free. Try it for a few issues and see if you like it. Subscribe at:

[www.StarFleetGames.com/newsletter.shtml](http://www.StarFleetGames.com/newsletter.shtml)

## We Welcome Your Ideas

Really! We do! If you have an idea of a way we can make life easier for our players, just let us know and we will at least see if we can make it happen.

# REVISED SHIP CARD

## WYN AUXILIARY CRUISER

FLEET SCALE

WDS \_\_\_\_\_  
Name

MARINES  
2

FRAME  
DAMAGE  
1

This ship has  
no probe  
launcher.

TURN MODE C MOVE COST 1/8
BASE SPEED 8 TURN MODE 2 SPEED COST 1
BASE SPEED 16 TURN MODE 3 SPEED COST 2
BASE SPEED 24 TURN MODE 5 SPEED COST 3
ACCELERATION COST 1/8
DECELERATION COST 1/8
HIGH ENERGY TURN COST 5/8
EVASIVE MANEUVER COST 3/4

142

COUNTER AXC  
 POINT VALUE: 33  
 DAMAGE CONTROL: 2

#6

SHIELD #1

5

#2

DRONE RACK A

OPT HULL 360° HULL OPT  
A C C B  
LS RS

BRDG

SYS SHTL

REACTOR

BTTY PH-1 BTTY  
360°

IMP

LEFT WARP 2 RIGHT WARP 2

See rules for optional  
weapons:  
Phaser-1, Drone-360°,  
Disruptor (25 hexes).

SHIELD #4

5

DRONE RACK B

#5

WEAPONS USED

1
2
A
B

POWER TRACK

12

11

10

9

8

7

6

5

4

3

2

1

0

FRACTIONAL POWER

0    1/8    1/4    3/8    1/2    5/8    3/4    7/8

FEDERATION COMMANDER: HYDRAN ATTACK  
FLEET SCALE SHIP CARD #142 of 129-144  
Copyright © 2009 Amarillo Design Bureau, Inc.

There was nothing "wrong" with the original Ship Card for this vessel. Indeed, we just published it in *Hydran Attack* a few days ago, but it is the most common WYN ship and we thought it should be available as a PDF.

The publisher of this game grants permission to players to make a reasonable number of photocopies of this page (up to 25 per month) for the personal use of the player. Reproduction for sale is **not authorized.**

# REVISED SHIP CARD

## WYN AUXILIARY CRUISER SQUADRON SCALE

COUNTER **AXC**  
POINT VALUE: 65  
DAMAGE CONTROL: 4

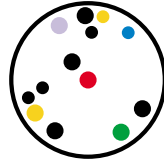

### POWER TRACK

- 24
- 23
- 22
- 21
- 20
- 19
- 18
- 17
- 16
- 15
- 14
- 13
- 12
- 11
- 10
- 9
- 8
- 7
- 6
- 5
- 4
- 3
- 2
- 1
- 0

WDS \_\_\_\_\_  
Name

MARINES  
4

FRAME DAMAGE  
2

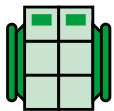

This ship has no probe launcher.

TURN MODE C MOVE COST 1/4
BASE SPEED 8 TURN MODE 2 SPEED COST 2
BASE SPEED 16 TURN MODE 3 SPEED COST 4
BASE SPEED 24 TURN MODE 5 SPEED COST 6
ACCELERATION COST 1/4
DECELERATION COST 1/4
HIGH ENERGY TURN COST 1+1/4
EVASIVE MANEUVER COST 1+1/2

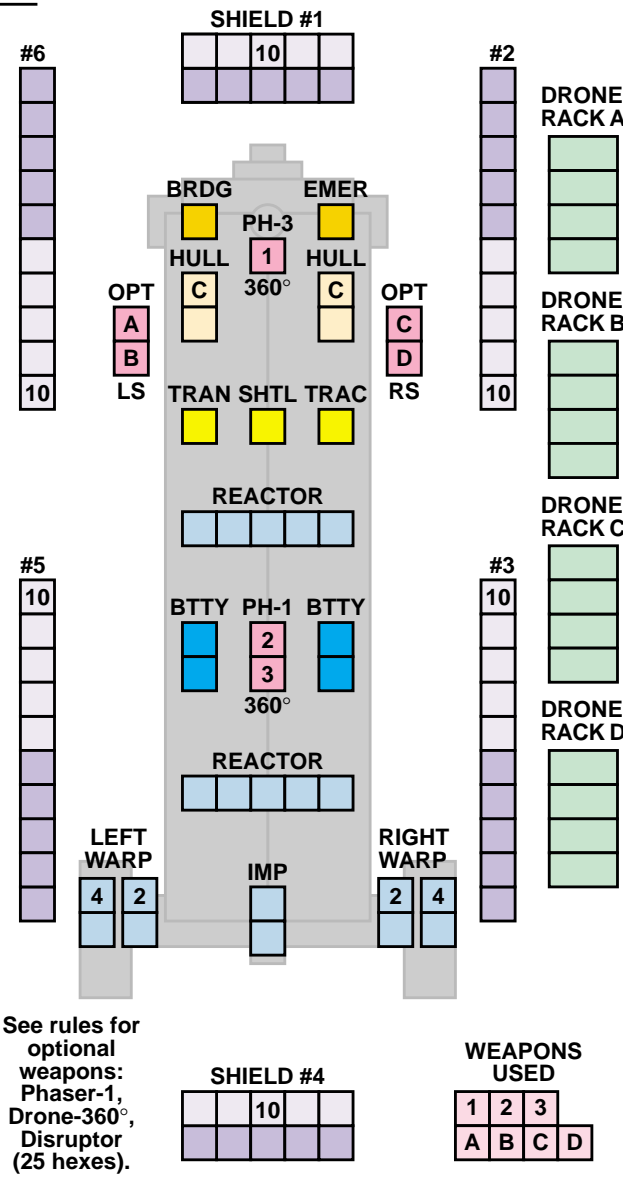

See rules for optional weapons: Phaser-1, Drone-360°, Disruptor (25 hexes).

There was nothing "wrong" with the original Ship Card for this vessel. Indeed, we just published it in *Hydran Attack* a few days ago, but it is the most common WYN ship and we thought it should be available as a PDF.

The publisher of this game grants permission to players to make a reasonable number of photocopies of this page (up to 25 per month) for the personal use of the player. Reproduction for sale is **not authorized.**

# NEW SHIP CARD

## BORDERS OF MADNESS

### HYDRAN NEW SCOUT CRUISER

FLEET SCALE

COUNTER NSC  
 POINT VALUE: 65+30  
 DAMAGE CONTROL: 2

POWER TRACK

17

16

15

14

13

12

11

10

9

8

7

6

5

4

3

2

1

0

This ship is scheduled for *Briefing #3*.

PROBES

MARINES

4

WEAPONS USED

A	B
1	2

PH-G

3

FRAME DAMAGE

3

TURN MODE B MOVE COST 3/8
BASE SPEED 8 TURN MODE 2 SPEED COST 3
BASE SPEED 16 TURN MODE 3 SPEED COST 6
BASE SPEED 24 TURN MODE 4 SPEED COST 9
ACCELERATION COST 3/8
DECELERATION COST 3/8
HIGH ENERGY TURN COST 1+7/8
EVASIVE MANEUVER COST 2+1/4

HMS \_\_\_\_\_  
 Name

SHIELD #1

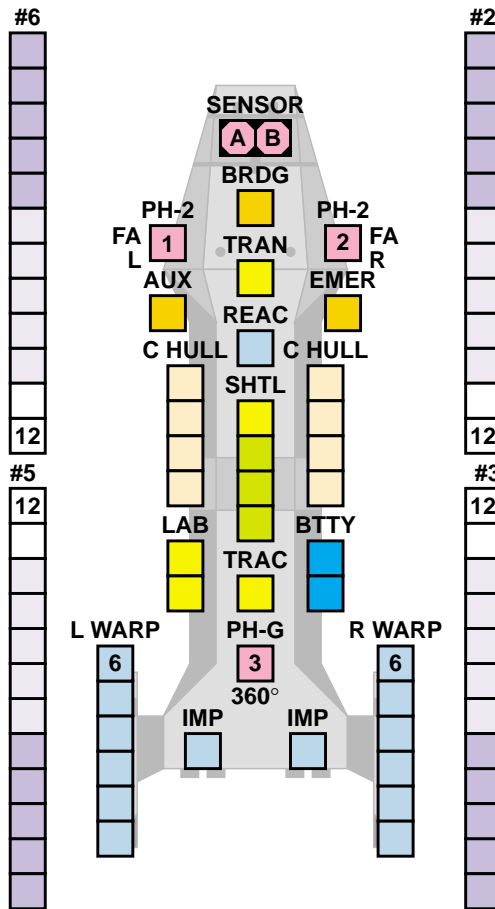

SHIELD #4

FEDERATION COMMANDER: BRIEFING #3  
 FLEET SCALE SHIP CARD #F3YY  
 Copyright © 2009 Amarillo Design Bureau, Inc.

F3YY

0 1/8 1/4 3/8 1/2 5/8 3/4 7/8

FRACTIONAL POWER

The publisher of this game grants permission to players to make a reasonable number of photocopies of this page (up to 25 per month) for the personal use of the player. Reproduction for sale is **not authorized**.

# NEW SHIP CARD

## BORDERS OF MADNESS

**HYDRAN NEW SCOUT CRUISER**  
**SQUADRON SCALE**

COUNTER NSC  
 POINT VALUE: 130+60  
 DAMAGE CONTROL: 4



**POWER TRACK**

This ship is scheduled for *Briefing #3*.

HMS \_\_\_\_\_  
 Name

MARINES

8			
4			

PROBES

--	--	--	--

WEAPONS USED

A	B	C	D
1	2	3	4

PH-G

5	6

FRAME DAMAGE

5			
---	--	--	--

TURN MODE B  
 MOVE COST 3/4

BASE SPEED 8  
 TURN MODE 2  
 SPEED COST 6

BASE SPEED 16  
 TURN MODE 3  
 SPEED COST 12

BASE SPEED 24  
 TURN MODE 4  
 SPEED COST 18

ACCELERATION  
 COST 3/4

DECELERATION  
 COST 3/4

HIGH ENERGY  
 TURN COST 3+3/4

EVASIVE MANEUVER  
 COST 4+1/2

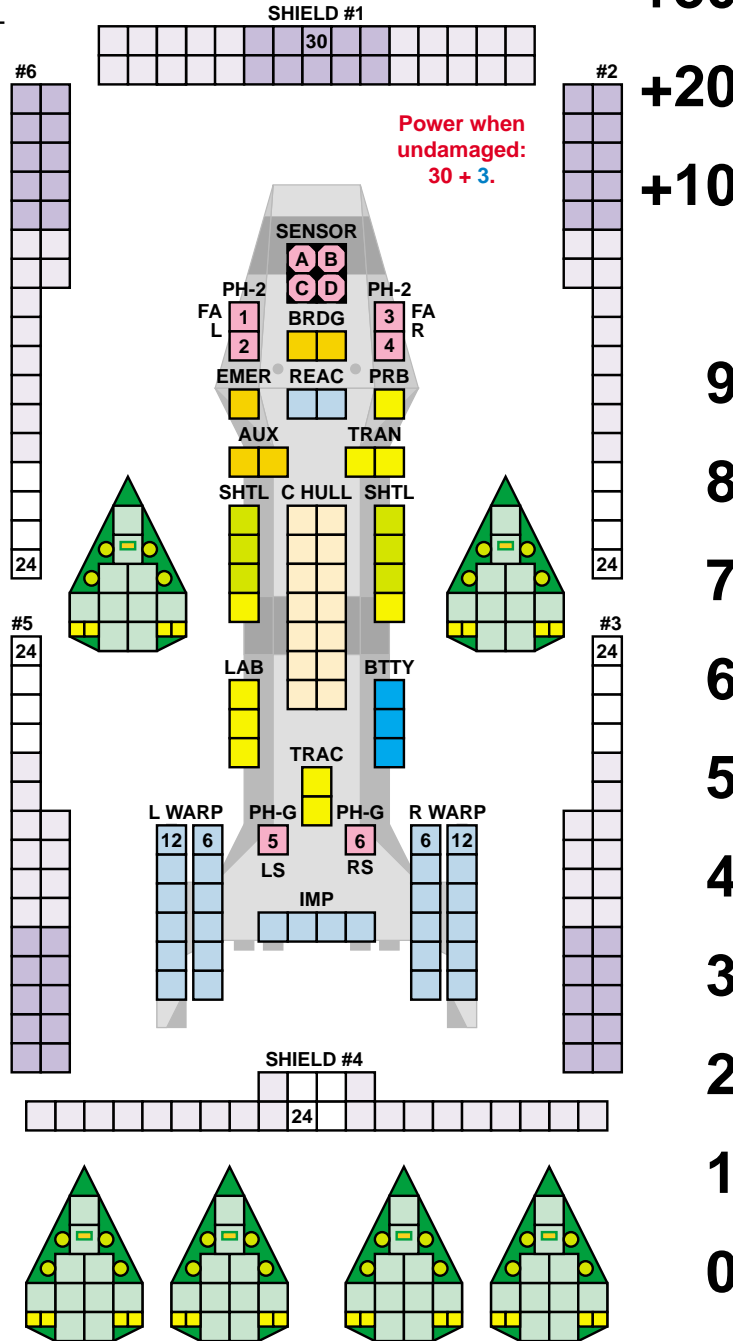

FEDERATION COMMANDER: BRIEFING #3  
 SQUADRON SCALE SHIP CARD #F3YY  
 Copyright © 2009 Amarillo Design Bureau, Inc.

**FRACTIONAL POWER**  
 0 1/4 1/2 3/4

The publisher of this game grants permission to players to make a reasonable number of photocopies of this page (up to 25 per month) for the personal use of the player. Reproduction for sale is **not authorized**.

# NEW SHIP CARD

## BORDERS OF MADNESS

### LYRAN SERVAL WAR CRUISER SCOUT

*FLEET SCALE*

COUNTER CWS  
POINT VALUE: 78  
DAMAGE CONTROL: 2

POWER TRACK



MARINES

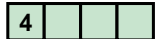

PROBES

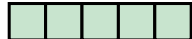

LMS \_\_\_\_\_  
Name



FRAME DAMAGE



Ships of the LDR have two PH-Gs (LS/RS) instead of the two PH-3s. BPV = 85.

PH-G

PH-2 #1 is a PH-1 on LDR ships.

TURN MODE B  
MOVE COST 3/8

BASE SPEED 8  
TURN MODE 2  
SPEED COST 3

BASE SPEED 16  
TURN MODE 3  
SPEED COST 6

BASE SPEED 24  
TURN MODE 4  
SPEED COST 9

ACCELERATION  
COST 3/8

DECELERATION  
COST 3/8

HIGH ENERGY  
TURN COST 1+7/8

EVASIVE  
MANEUVER  
COST 2+1/4

F3XX

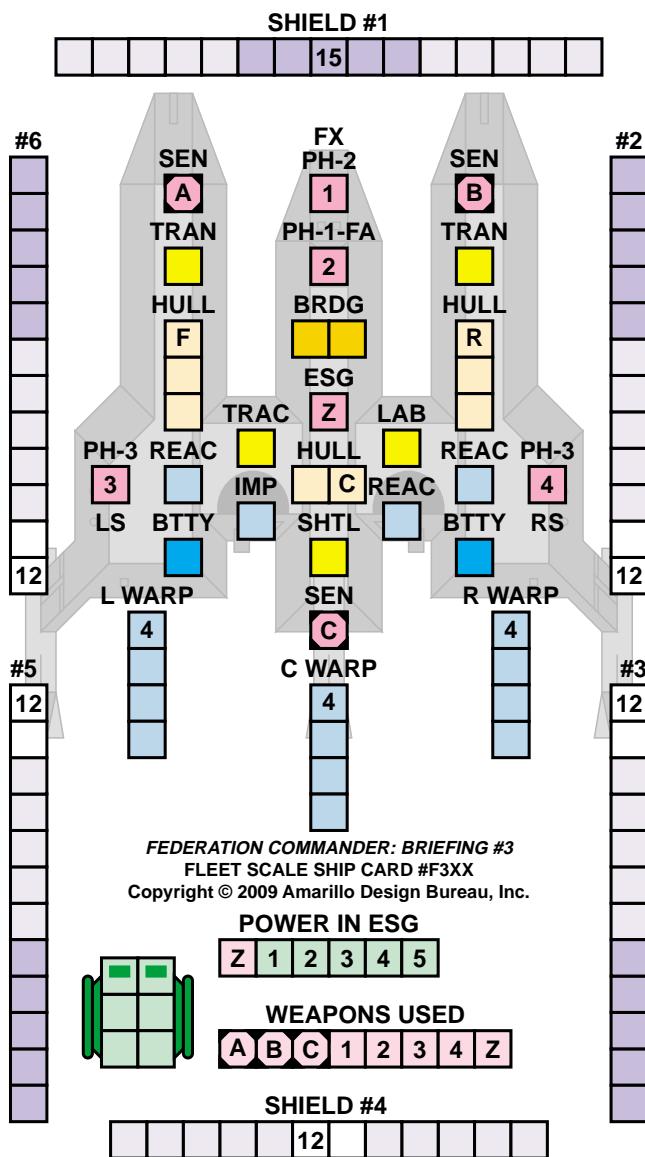

FEDERATION COMMANDER: BRIEFING #3  
FLEET SCALE SHIP CARD #F3XX  
Copyright © 2009 Amarillo Design Bureau, Inc.

POWER IN ESG

WEAPONS USED

This ship is scheduled for *Briefing #3*.

The publisher of this game grants permission to players to make a reasonable number of photocopies of this page (up to 25 per month) for the personal use of the player. Reproduction for sale is **not authorized**.

# NEW SHIP CARD

## BORDERS OF MADNESS

**LYRAN SERVAL**  
**WAR CRUISER**  
**SCOUT**  
*SQUADRON SCALE*

COUNTER CWS  
 POINT VALUE: 144  
 DAMAGE CONTROL: 4

**POWER TRACK** +30



+20

+10

This ship is scheduled for *Briefing #3*.

LMS \_\_\_\_\_  
 Name

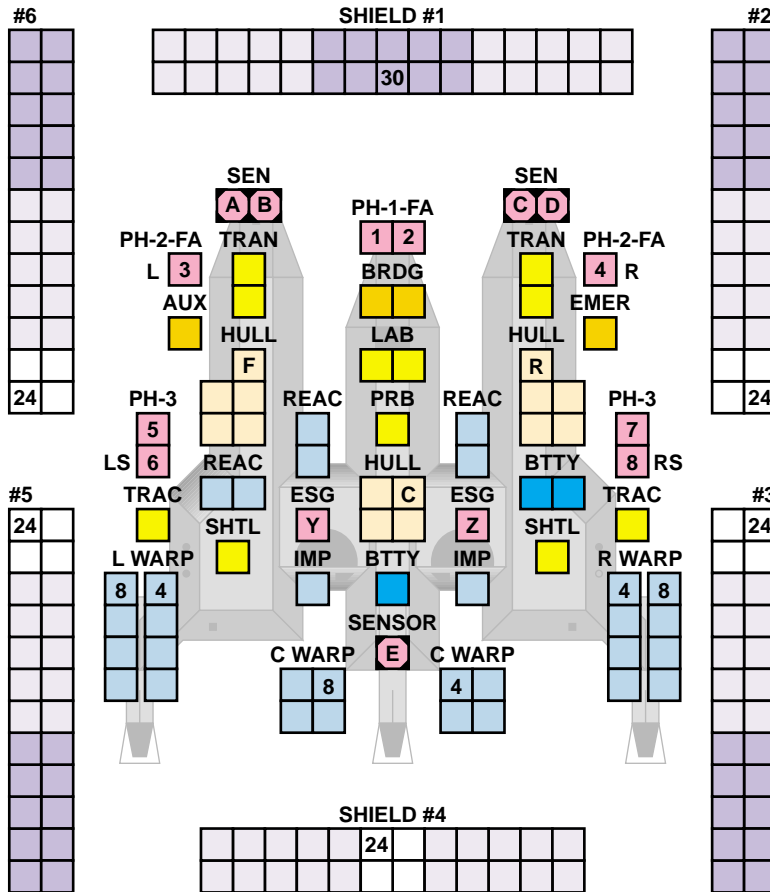

Power when undamaged:  
 32 + 3.

9

8

7

6

5

4

3

2

1

0

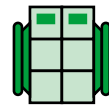
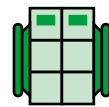

WEAPONS USED

A	B	C
D	E	1
2	3	4
5	6	7
8	Y	Z

<b>ACCELERATION</b> COST 3/4	<b>TURN MODE B</b> MOVE COST 3/4
<b>DECELERATION</b> COST 3/4	<b>BASE SPEED 8</b> TURN MODE 2 SPEED COST 6
<b>HIGH ENERGY</b> TURN COST 3+3/4	<b>BASE SPEED 16</b> TURN MODE 3 SPEED COST 12
<b>EVASIVE MANEUVER</b> COST 4+1/2	<b>BASE SPEED 24</b> TURN MODE 4 SPEED COST 18

Ships of the LDR have four PH-Gs instead of four PH-3s.  
 BPV = 158.

PH-G

5			
6			
7			
8			

MARINES

8			
4			

FRAME DAMAGE

5				
---	--	--	--	--

PROBES

--	--	--	--	--

PH-2 #3-#4 are PH-1 on LDR ships.

POWER IN ESGs

Y	1	2	3	4	5
Z	1	2	3	4	5

**FRACTIONAL POWER**  
 0 1/4 1/2 3/4

The publisher grants permission to players to make up to 25 photocopies of this page per month (and to print on his own printer as many as he wants) for personal use. Reproduction for sale is **not authorized**.



FEDERATION COMMANDER: BRIEFING #3  
 SQUADRON SCALE SHIP CARD #F3XX  
 Copyright © 2009 Amarillo Design Bureau, Inc.



# KLINGON C10 HEAVY DREADNOUGHT SQUADRON SCALE

COUNTER C10  
POINT VALUE: 278  
DAMAGE CONTROL: 6



**POWER TRACK**

Power when undamaged: 59 + 10.

IKV \_\_\_\_\_  
Name

**ANTI-DRONES IMP USED**

1	2	3	4	5	6	7	8
---	---	---	---	---	---	---	---

**WEAPONS USED**

A	B	C	D	E	F
1	2	3	4	5	6
7	8	9	10	11	12
13	14	15	16	17	18
S	T	U	V	W	X
Y	Z				

**PROBES**

--	--	--	--

**MARINES**

24			
20			
15			
10			
5			

**FRAME DAMAGE**

8		
4		

**TURN MODE D  
MOVE COST 1+1/2**

BASE SPEED 8  
TURN MODE 2  
SPEED COST 12

BASE SPEED 16  
TURN MODE 4  
SPEED COST 24

BASE SPEED 24  
TURN MODE 5  
SPEED COST 36

ACCELERATION  
COST 1+1/2

DECELERATION  
COST 1+1/2

HIGH ENERGY  
TURN COST 7+1/2

EVASIVE  
MANEUVER  
COST 9

FEDERATION  
COMMANDER:  
BOOSTER PACK #17  
SQUADRON SCALE SHIP  
CARD #87 OF 81-96  
Copyright © 2007  
Amarillo Design Bureau, Inc.

**87**

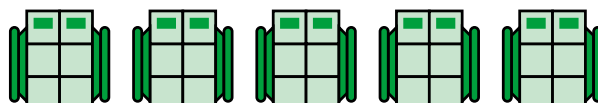

**FRACTIONAL POWER**  
0 1/2

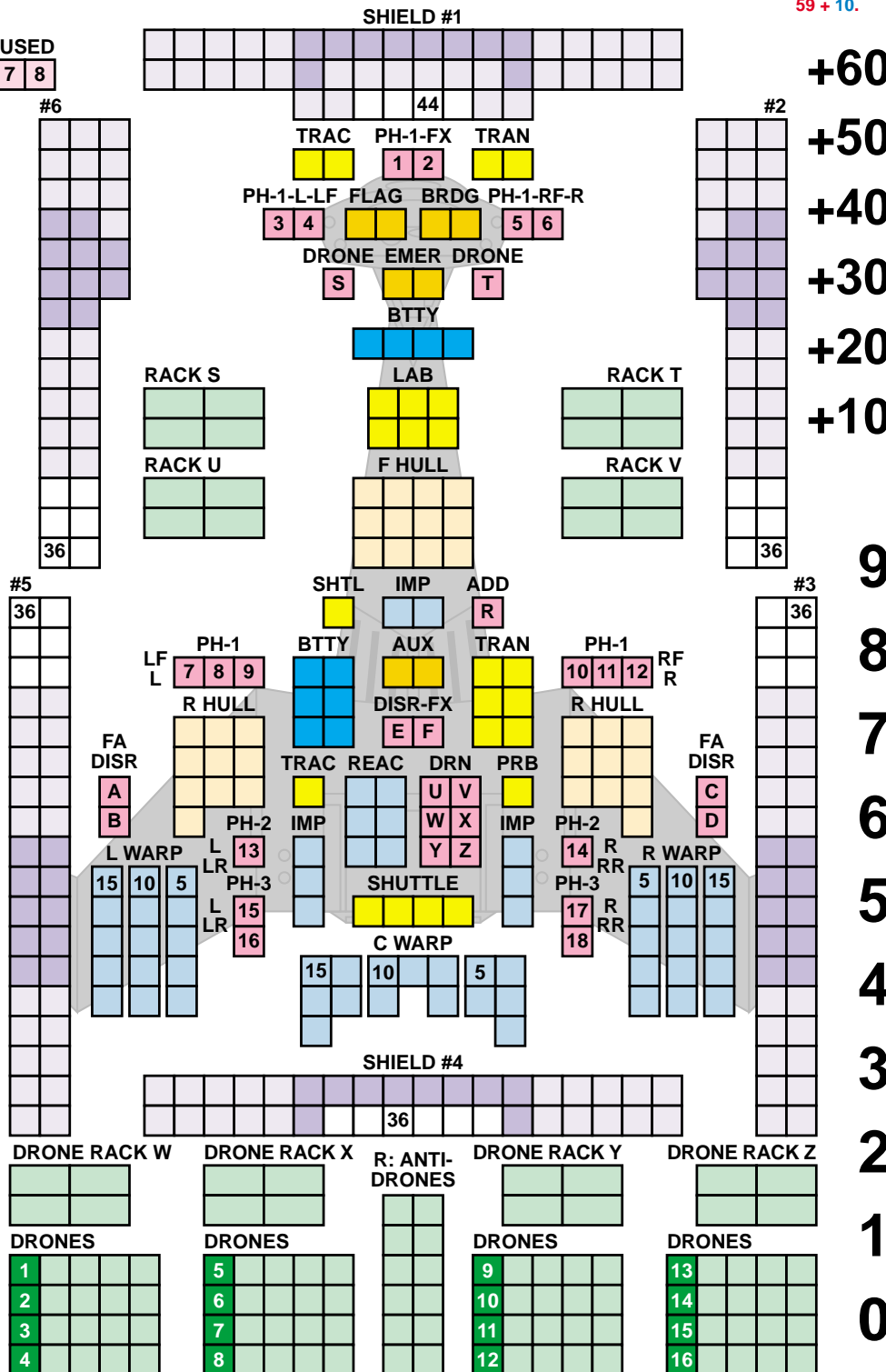

The publisher of this game grants permission to players to make a reasonable number of photocopies of this page (up to 25 per month) for the personal use of the player. Reproduction for sale is not authorized.

**LARGER SHIP CARD**