

# KLINGON F-5 FRIGATE

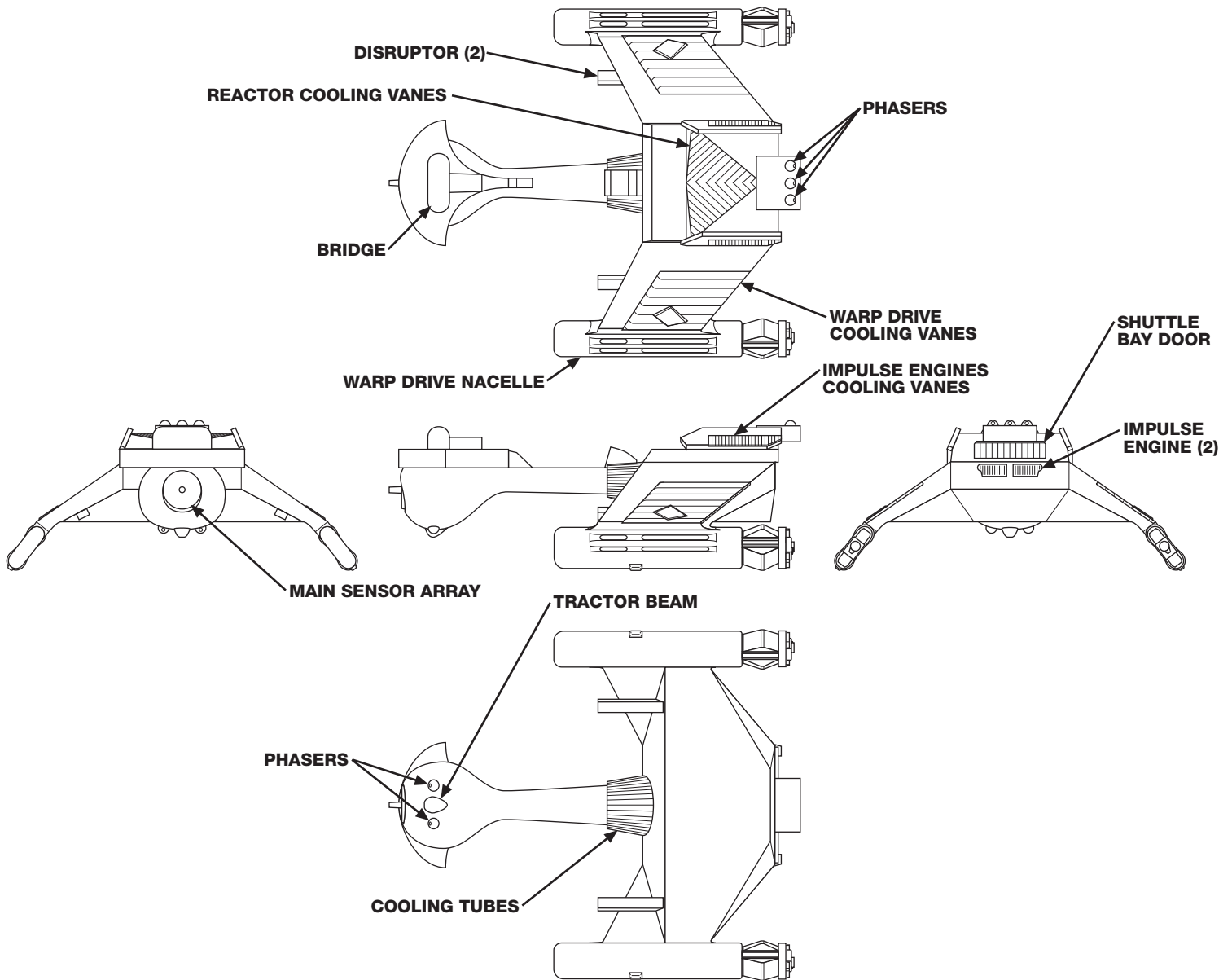

## PARTICULARS

**DEADWEIGHT TONNAGE (METRIC): 56,000**  
**LENGTH OVERALL (METERS): 99.49**  
**WIDTH OVERALL (METERS): 89.48**  
**HEIGHT OVERALL (METERS): 40.31**  
**CREW (TOTAL): 220**  
**CRUISING SPEED: W/F 6**  
**DISRUPTORS: 2**  
**PHASERS (TYPE-2): 5**  
**SHUTTLECRAFT**  
**(ADMINISTRATIVE, OPERATIONAL): 1**