



# FEDERATION COMMANDER



## COMMUNIQUE #5 STARDATE 2006.05

### NEW SHIPS

Included in this issue are two new Fleet Scale ships to use with your *Romulan Border* or *Booster Zero* rules. These include the Romulan Sparrowhawk and the Gorn Battle Destroyer.

### SCHEDULE UPDATE

We shipped *Boosters #1, #2, and #3* on 6 March.

We shipped *Klingon Attack* and *Squadron Boxes #4, #5, and #6* on 29 March.

We shipped *Boosters #4, #5, and #6* on 10 April.

We shipped *Booster Zero* on 26 April. *Booster Zero* includes ships and rules from six new empires: the Romulans, Gorns, Lyrans, Hydrans, ISC, and the WYN Star Cluster.

We released *Border Box #2* in early June.

We released *Romulan Border* at Origins.

We expect to ship *Booster 7, Booster 8, Booster 9, Squadron Box 7, Squadron Box 8, and Squadron Box 9* during July.

We expect to release *Border Box #3* in August.

We expect to release *Romulan Attack* in September.

### REVISION-4 RULEBOOK RELEASED

*Romulan Border* included a rulebook based on the Rev-3 *Klingon Border* rulebook. This included several rules updates (listed on the next page) and constitutes a Revision-4 rulebook.

After that, we rebuilt the *Klingon Border* rulebook into a new Rev-4 rulebook. If you bought *Romulan Border*, you already have all of these rules updates but may not have noticed them. We want both *Borders* to be "entry gateway products" so that either one of them will support all other products. This means that the *Klingon Border Rev-4* rulebook now includes the plasma torpedo and cloaking device rules that it originally did not.

You can obtain the latest revision of the rulebook for \$3 plus postage on our shopping cart:

[http://www.starfleetstore.com/MERCHANT2/  
merchant.mv?Screen=PROD&Store\\_Code=S&Product\\_  
Code=4001-2](http://www.starfleetstore.com/MERCHANT2/merchant.mv?Screen=PROD&Store_Code=S&Product_Code=4001-2)

The rulebook is priced (as a spare part) at \$10, but you can get the "trade-in" price (without actually trading anything in) by using "special instructions" to tell us that you are upgrading a rulebook you bought. This trade-in offer is (obviously) available only to people who bought the game (or a rulebook) in the first place. You need to either have bought the game from us (tell us this so we can confirm you actually bought a rulebook in the first place) or give us the complete name, address, and phone number of the store where you bought it.

### PUBLISHER'S INFORMATION

*FEDERATION COMMANDER: COMMUNIQUE #5* is published and copyright © 2006 by Amarillo Design Bureau, [www.starfleetgames.com](http://www.starfleetgames.com), PO Box 8759, Amarillo TX 79114.

Elements of the Star Fleet Universe are the property of Paramount Pictures Corporation and are used with their permission.

## FEDERATION COMMANDER Organized League Play

The on-line forms for registering your store as a site for Organized League Play are live on the web site. Also available is the form to register your completed games, and you can even use the same form to register future games as a means of inviting people to attend and join the fun.

You will find these forms at [www.federationcommander.com](http://www.federationcommander.com) along with everything else for this game system.

Many stores have already signed up, and the first round of prizes (a series of six "bonus cards" used to give ships a special ability) are being mailed out to those stores.

The scenario of the month for May is:

**(8KF) THE RAID ON RUKYVERK**

This scenario is in *Klingon Attack*.

## NEWS FOR COMMANDERS

### FEDERATION COMMANDER VICTORY AT ORIGINS 2006

Propelled by the success of *Federation Commander: Romulan Border*, Amarillo Design Bureau Inc. set a major sales record at Origins of over ten thousand dollars. This was our best Origins ever, and was 80% above last year's sales.

Dozens of players took part in the first-ever *Federation Commander* National Championships, and Commander Patrick Doyle won the event in a dramatic victory over Vice-Commander Clint Beck.

### Our Apologies for the Delay

This is supposed to be the May issue, and it was sent to the webmaster for uploading on 12 July. (The June issue will be along in about a week, the July issue in another week.)

Communique #4 explains why that issue was late, and the delay in #4 of course delayed everything else.

### THE BBS: KEYS TO COMMUNICATION

The BBS ([www.starfleetgames.com/discus](http://www.starfleetgames.com/discus)) can be confusing at first sight, as it has hundreds of topics, used daily by a thousand players. Registration is free, but we do require all participants to use their real names. (This not only improves the overall tone of civility, but makes sure you get credit for any suggestions you make.) When you register, you will see topics for each of our product lines. Feel free to venture into the broader universe as you get more comfortable with the system.

# RULES UPDATES

The rulebook in *Federation Commander: Romulan Border* is an upgrade from the Revision-3 rulebook now shipping in *Federation Commander: Klingon Border*. It includes a number of minor but important rules clarifications, which are quoted below for those who have *FCKB3* rulebooks. We expect to produce (in a few days) a new *FCKB4* rulebook incorporating these upgrades and include it in new copies of *FCKB*.

**(1E2c) Defensive Fire Phase: STEP 1.** If the seeking weapon is a drone **which impacted on the current impulse**, it could be engaged by an anti-drone (4E) if the ship has that system.

**(1E3b) Weapons Records:** Erase any marked letters on the “weapons used” track so those weapons can be used again on the next turn. This procedure is used because each weapon can only be used once per turn (once per impulse for anti-drones). **At this time, calculate lab points gained (5B3).** If a lab was disabled during the turn, count the closest point the ship was to the target when the lab was active.

**(2D4a) Energy Cost:** At the end of the Defensive Fire Phase (1E2c) of any Impulse, you *may* announce Evasive Maneuvers. **You may only do this once in any given turn.**

**(2D4d) Termination:** Evasive Maneuvers continue until the end of the turn or until the player controlling the ship decides (during the Speed Change Phase of a subsequent Impulse) to cancel Evasive Maneuvers. This cancellation cannot be made until two impulses after the announcement, so a ship which announced it on the Defensive Fire Phase of Impulse #3 could cancel it on the Speed Change Phase of Impulse #6. (It could not be cancelled on Impulse #5 since at the time of the Speed Change Phase in that impulse the required two impulses had not elapsed.) **Evasive Maneuvers do not continue into the next turn (unless power is spent in the Energy Allocation Phase of that turn, which counts as the one time you can adopt Evasive Maneuvers for that turn).**

## (3C5) SHIELD REINFORCEMENT

Shields can be reinforced. Whenever a volley of damage strikes an active shield, the player who controls that ship has the option to use a number of his remaining Energy Tokens (up to the number of working batteries) to absorb some of the damage. Each Energy Token blocks one point of damage. See the rules below on Damage Allocation (3D). Note that while batteries limit the amount of power used on any given volley, you can use that much power against *every* volley, even if you

used it on a previous volley of the same or a different impulse. **A shield that is down cannot be reinforced by batteries.**

**(4F5c) Counter-weapons:** You can target a seeking weapon on the enemy seeking weapon. The impact of any drone or plasma torpedo on another drone will destroy that drone. Seeking weapons will damage (and possibly destroy) any suicide shuttles or suicide freighters. No seeking weapon can target a plasma torpedo. Suicide shuttles cannot target drones.

If seeking weapon A is targeted on seeking weapon B, and B impacts its target before A reaches it, then A is removed and B is treated as an impact. **If A and B both reach the target of B on the same sub-pulse (or if B hits A, which previously impacted and was stopped by a tractor beam), BOTH impact that shield of the target and BOTH cause damage (and either or both could be stopped by defensive fire).** (Tactical note, drop tracking to your seeking weapon before allowing this to happen.) If A hits B before B reached the target, A and B are destroyed and the target is unaffected.

## (5L1) ORION OPTIONAL WEAPONS

Orion ships have their main heavy weapon marked WPN instead of what kind of weapon it is. This is because pirate ships operate across the galaxy and their captains outfit them with whatever weapons are available. The Orion player may, before each scenario begins, decide (and announce) if a WPN box holds a photon torpedo (FA), a disruptor (FA), a drone rack (360°), fusion beam (FA), hellbore (FA), ESG (360°) or a phaser-1 or G (FA), or other weapons. Each WPN box can be given a separate identity.

The Orion player could experiment with changing the drone racks on the Salvage Cruiser and Raider Cruiser to phaser-1s (LS on the left wing, RS on the right wing) or plasma-F (LP on the left wing, RP on the right wing). The wing mounts cannot hold other types of weapons. The Fleet Scale CR uses a 360° phaser and FP plasma tracking are for its wing box.

The Light Raider (in *Klingon Attack*) is a special case. It has two “wing” option mounts (one in each wing) and these can hold drone racks (360°), Plasma-Fs (LP and RP), Phaser-1 or Phaser-G (LS and RS), anti-drones (360°), Disruptors (Range 15, FA *or* L+LF and RF+R), Photons (FA *or* L+LF and RF+R), or Fusion Beams (FA *or* L+LF and RF+R).

The same rule applies to an Orion base but all of its weapons are “hull mounted” not “wing-mounted”.

Orions never used phaser-4s and any phaser-4s on the base card are replaced by phaser-1s when it is used as an Orion base.

# FEDERATION COMMANDER SCENARIO

## [8C3] THE BATTLE OF JUGGERNAUT ALPHA

Having determined what kind of enemy they are facing, captains from four races (none of which are friends) forge an alliance to destroy the extra-galactic ship before it attacks any of their colonies.

*This scenario was published in Captain's Log #33 and reflects the battle against the first Juggernaut, which was portrayed in a story published in Captain's Log #1 in 1983. Yes, the Star Fleet Universe has been around for that long, and in fact even longer. It started in 1979.*

### (8C1A) NUMBER OF PLAYERS

Two, the "Juggernaut" player (who controls the Juggernaut) and the "allies" (who are here to destroy it). The "allies" (temporary allies of convenience) include Federation, Klingon, Tholian, and Orion ships.

### (8C1B) INITIAL SET UP

Lay out the six map panels three wide and two high, using the small size hexes. For convenience, call these A (upper left), B (upper center), C (upper right), D (lower left), E (lower center), and F (lower right). You can use the larger size hexes if you use more panels (three high by five wide).

The map will float in any direction.

Set up the Juggernaut in the center of the map (Panel B, hex 0715) facing in direction B.

Set up the Federation Command Cruiser *Excalibur* (from Booster #1) in Panel D, hex 0115. Set up the Klingon D7C Command Cruiser *Darkslayer* (from Booster #2) in Panel C, hex 1401. Set up the Tholian Heavy Cruiser *Arraak* (from Booster #3) in Panel A, hex 0101. Set up the Orion Raider *Gossamer Phoenix* (from Klingon Attack) in Panel F, hex 1415. All of these ships will face the Juggernaut.

There is a planet 200 hexes in direction B from the Juggernaut. The Juggernaut wants to destroy the colony on this planet.

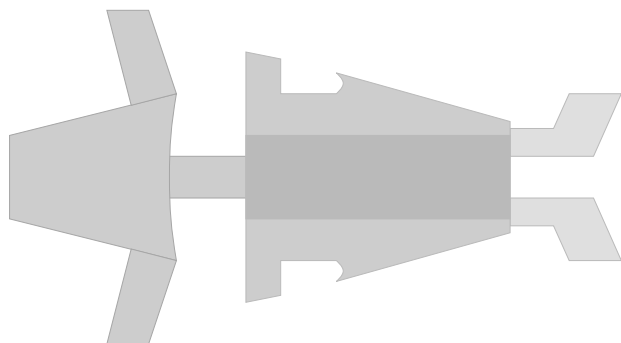

### (8C1C) OBJECTIVE

**Allies Mission:** The mission of the attacking force is to destroy the Juggernaut. Any other result is a failure. Ship losses suffered by the allies are not relevant.

**Juggernaut Mission:** Score 300 points of damage on the planet, *and* destroy (or force the disengagement of) all four of the ships. Any other result is a failure.

**Time Limit:** This scenario has no time limit.

### (8H4) SPECIAL RULES

Any allied ship which moves to a hex more than 25 hexes from the Juggernaut is considered to have disengaged. Such a ship is removed from the scenario immediately and takes no further part in the battle.

The Orion CR has a cloak (costs one energy token).

### (8H5) FORCE DYNAMICS

The balance of the scenario can be adjusted by giving the allies a stronger or less effective force.

You could replace the Federation Command cruiser with a Dreadnought (vastly stronger) Battlecruiser (stronger), New Heavy Cruiser (marginally stronger), Heavy Cruiser (marginally less effective), New Light Cruiser (somewhat less effective), Light Cruiser (much less effective), Destroyer (from Communicate, much less effective), or Frigate (much less effective).

You could replace the Klingon D7C with a C8 (vastly stronger), C7 (stronger), D5W (marginally stronger), D5 or D6 (slightly less effective), or F5 (much less effective).

You could replace the Tholian Heavy Cruiser with a War Cruiser from Communicate (slightly less effective), with a Destroyer or Patrol Corvette (much less effective), or with a destroyer *and* a patrol corvette (about as effective).

You could replace the Orion CR with two LR's (about as effective) or one LR (much less effective). —*Steve Cole*

In  
your  
Store  
Now!

FEDERATION  
COMMANDER:  
ROMULAN  
BORDER



## FED COMMANDER TACTICS

### Initial Tactical Thoughts

— *Fleet Captain Sandy Hemenway*

SFB players will have a certain amount of trouble adjusting to the new tactics in *Federation Commander*, perhaps enough time for new players to get ahead and stay ahead of them. Here are three specific points which caught my eye.

*Federation Commander* is more like Chess and less like *Stratego*. Out-guessing your enemy still exists in your tactics and maneuvers, but not in Energy Allocation. Since everything is (more or less) reserve power, and this is always public knowledge, you will always know if your opponent can overload his weapons (or already overloaded his photons). Your opponent can no longer “brick” (put a huge amount of unknown shield reinforcement in one shield) because of the battery rules. There will also be much less surprise in tractor auctions; you may decide to give up but you will know before it starts if you cannot win (unless he gives up trying, which in some cases he might).

Without Wild Weasels to block, closing in for an “anchor” attack isn’t that necessary (unless you just don’t want him to run away from seeking weapons). With a range of only one hex, tractors will be limited to drone defense and towing friendly ships.

“It’s the Phasers, Stupid!” In a game where the enemy’s energy is always known, *efficient* use of power will be critical. In that regard, phasers (especially Phaser-1s) will become the primary weapon system. Torpedoes will fall to second place and will be armed only when you know you have power for everything that you want to do. Two points in a disruptor will get four damage while those same two points in two phaser-1s will get twice as much (if you’re close enough). There will be times when the all-or-nothing firepower of a heavy weapon is preferable, but in general terms and with limited power, phasers are always going to be your “go to weapon”.

### Hack And Slash just got a lot tougher

— *Ensign Robert W. Eldridge*

One of the most significant tactical changes from SFB is that with four “movement sub-pulses” for each firing opportunity (and the acceleration rules will always let your target use more of them than he thought he would need), there are no more “drop his shield on one impulse and hammer him on the next” shots. SFB was always so much fun because you could use those leftover phasers on Impulse #32 to weaken a shield, then use Energy Allocation to load up the heavy weapons for the crippling blow (since there were few ways to turn a new shield in Impulse #1, and those all came with drawbacks so nobody wanted to make a habit of using them).

The target is always going to be able to move (perhaps as many as four times!) and getting a second shot

on the same down shield is going to be tough. You need to really learn maneuvering, specifically closer-quarter battle tactics, if you want to get that followup shot. Of course, you can still move, turn, sideslip, and even do a high energy turn, but you can also accelerate or decelerate, which gives a whole new dimension to maneuver.

### Run And Gun

— *Cadet Dave Adams*

*Federation Commander* is a high-speed game in more ways than one. You need to get the job done in record time!

Stay fast, since you can always “decelerate” and faster speed means you get to move last.

Flying your Klingon D7 into overload range of a Federation ship *before* his photons get hot is not just a survival move, it’s a winning move.

Stack the drones. Pile them on. Launch, move with them, launch some more. There are no transporter bombs and no wild weasels, so you don’t have to stagger them out. Pile them high! Keep them in close formation so the same shield and the same defensive weapons have to deal with the whole stack.

## WHAT SHIPS DO YOU WANT?

Here is your chance to get what you want. Whether you are a veteran player of *Star Fleet Battles* and familiar with the thousands of starships in that game system, or a new player of *Federation Commander* and just have a vague feeling that some ship of some kind is missing from your fleet, tell us what you want and we’ll consider adding it via *Communique* or in a future expansion.

This issue includes an updated and corrected version of the Federation Destroyer from *Communique #3*. While we have re-uploaded that issue, it is easier on you players to just include a copy here.

Players requested “fleet scale small freighters” and those were included in *Romulan Border* because we could not figure out how to make fleet scale versions of the tiny Armed Priority Transports. Of course, we did finally figure out how to do those and have put them in *Romulan Attack* on the back of the Squadron Scale Heavy Freighter (since the Squadron Scale Large Freighter works nicely as a Fleet Scale Heavy Freighter).

Players have asked us to include the original Franz Joseph dreadnought and the Klingon F5W War Destroyer in a future issue of *Communique* and we’ll get them done as soon as we can.

Now that *Romulan Border* has made the decision on Fleet Scale plasma torpedoes, we plan to do new Fleet Scale versions of the King Eagle, K7R, and ISC CA and put them in *Communique*.

*Captain’s Log* includes Fleet Scale War Cruisers for the Hydrans, Lyrans, WYNs, & ISC published in *Booster Zero*. We can always do more ships for these empires.





# NEW SHIP CARD

## ROMULAN SPARROWHAWK WAR CRUISER

*FLEET SCALE*

COUNTER

POINT VALUE: 83

DAMAGE CONTROL: 2

RIS \_\_\_\_\_  
Name



**POWER TRACK**

18  
17  
16  
15  
14  
13  
12  
11  
10  
9  
8  
7  
6  
5  
4  
3  
2  
1  
0

WEAPONS USED

A	1	2	3	4
---	---	---	---	---

PROBES

--	--	--	--	--

FRAME DAMAGE

--	--	--

MARINES

--	--	--

SHUTTLES

--	--	--

--	--	--

**CLOAK COST = 1**

TURN MODE B  
MOVE COST 3/8

BASE SPEED 8  
TURN MODE 2  
SPEED COST 3

BASE SPEED 16  
TURN MODE 3  
SPEED COST 6

BASE SPEED 24  
TURN MODE 4  
SPEED COST 9

ACCELERATION  
COST 3/8

DECELERATION  
COST 3/8

HIGH ENERGY  
TURN COST 1+7/8

EVASIVE MANEUVER  
COST 2+1/4

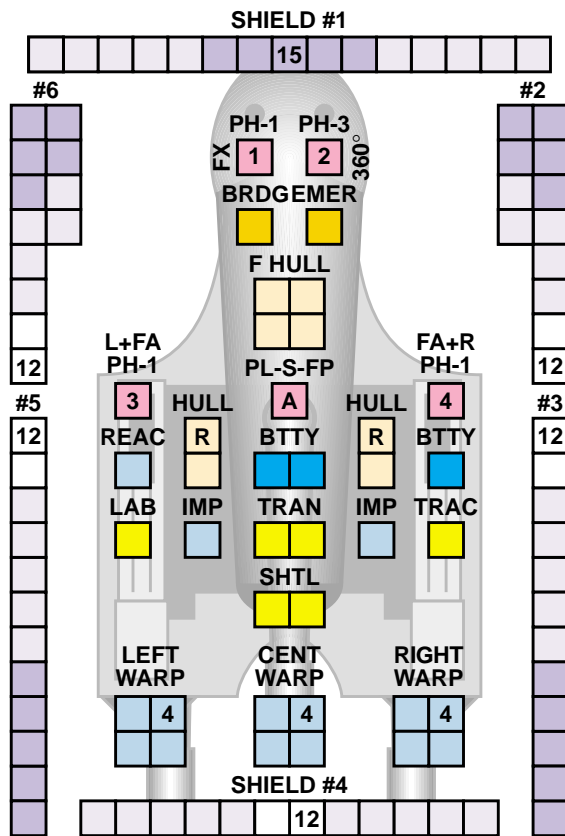

FEDERATION COMMANDER: ROMULAN ATTACK  
FLEET SCALE SHIP CARD #58 OF 49-64  
Copyright © 2006 Amarillo Design Bureau, Inc.

PLASMA A

--	--	--	--	--	--	--	--

PLASMA ARMING

A						G	S
---	--	--	--	--	--	---	---

**FRACTIONAL POWER**

0 1/8 1/4 3/8 1/2 5/8 3/4 7/8

**58**

The publisher of this game grants permission to players to make a reasonable number of photocopies of this page (up to 25 per month) for the personal use of the player. Reproduction for sale is not authorized.

# REVISED SHIP CARD

## GORN BATTLE DESTROYER

### FLEET SCALE

COUNTER   
 POINT VALUE: 49  
 DAMAGE CONTROL: 1

### POWER TRACK



13  
12  
11  
10  
9  
8  
7  
6  
5  
4  
3  
2  
1  
0

#### WEAPONS USED

A	B
1	2
3	

#### PROBES



#### MARINES

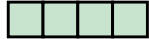

#### FRAME DAMAGE



#### SHUTTLES

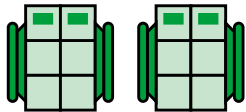

TURN MODE B MOVE COST 1/4
BASE SPEED 8 TURN MODE 2 SPEED COST 2
BASE SPEED 16 TURN MODE 3 SPEED COST 4
BASE SPEED 24 TURN MODE 4 SPEED COST 6
ACCELERATION COST 1/4
DECELERATION COST 1/4
HIGH ENERGY TURN COST 1+1/4
EVASIVE MANEUVER COST 1+1/2

GCS  
Name

#6  
10

#5  
10

SHIELD #1  
10

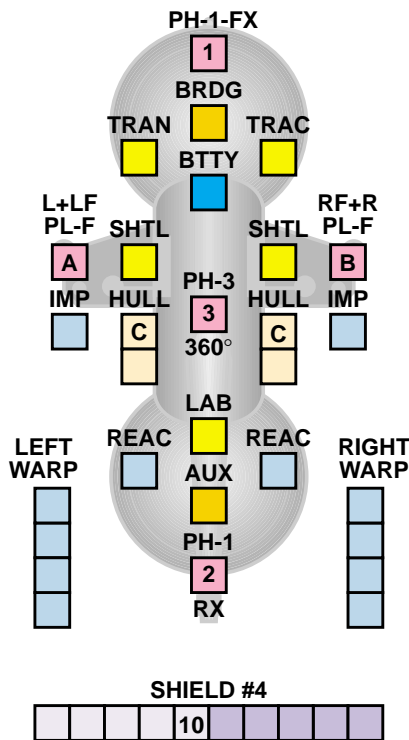

#2  
10

#3  
10

The Weapons Used track records that a weapon was fired during the current turn.

PLASMA A

--	--	--	--	--	--	--	--	--	--

PLASMA B

--	--	--	--	--	--	--	--	--	--

PLASMA ARMING

A					F
B					F

The publisher of this game grants permission to players to make a reasonable number of photocopies of this page (up to 25 per month) for the personal use of the player. Reproduction for sale is not authorized.