



FEDERATION COMMANDER



COMMUNIQUE #6

STARDATE 2006.06

NEW SHIPS

The Klingon F5W is well known to fans of *Star Fleet Battles*, and they requested it be provided for *Federation Commander* because the stalwart F5 is being beaten up by Fed Frigates.

Also in this issue is a slightly larger version of the Federation dreadnought for those who find the original one crowded. This was done on a player request. We can provide more of these "larger prints of crowded ships" if players want them.

SCHEDULE UPDATE

See Communique #5 for Boosters 0-6, Squadron Boxes 0-6, Klingon Attack, and Romulan Border.

We expect to ship *Booster 7, Booster 8, Booster 9, Squadron Box 7, Squadron Box 8, and Squadron Box 9* during July.

We expect to release *Border Box #3* in August.

We expect to release *Romulan Attack* in September.

REVISION-4 RULEBOOK RELEASED

Romulan Border included a rulebook based on the Rev-3 *Klingon Border* rulebook. This included several rules updates (listed in Communique #5) and constitutes a Revision-4 rulebook.

After that, we rebuilt the *Klingon Border* rulebook into a new Rev-4 rulebook. If you bought *Romulan Border*, you already have all of these rules updates but may not have noticed them. We want both *Borders* to be "entry gateway products" so that either one of them will support all other products. This means that the *Klingon Border Rev-4* rulebook now includes the plasma torpedo and cloaking device rules that it originally did not.

You can obtain the latest revision of the rulebook for \$3 plus postage on our shopping cart:

http://store.starfleetstore.com/merchant2/merchant.mvc?Screen=PROD&Store_Code=S&Product_Code=4001-2

The rulebook is priced (as a spare part) at \$10, but you can get the "trade-in" price of \$3 (without actually trading anything in) by using "special instructions" to tell us that you are upgrading a rulebook you bought. This trade-in offer is (obviously) available only to people who bought the game (or a rulebook) in the first place. You need to either have bought the game from us (tell us this so we can confirm you actually bought a rulebook in the first place) or give us the complete name, address, and phone number of the store where you bought it.

PUBLISHER'S INFORMATION

FEDERATION COMMANDER: COMMUNIQUE #6 is published and copyright © 2006 by Amarillo Design Bureau, www.starfleetgames.com, PO Box 8759, Amarillo TX 79114.

Elements of the Star Fleet Universe are the property of Paramount Pictures Corporation and are used with their permission.

FEDERATION COMMANDER Organized League Play

The on-line forms for registering your store as a site for Organized League Play are live on the web site. Also available is the form to register your completed games, and you can even use the same form to register future games as a means of inviting people to attend and join the fun.

You will find these forms at www.federationcommander.com along with everything else for this game system.

Many stores have already signed up, and the first round of prizes (a series of six "bonus cards" used to give ships a special ability) are being mailed out to those stores.

The scenarios of the months are:

March: (8KA) The Mighty *Hood* Goes Down (Klingon Attack)

April: (8KB) The Alkarik Convoy (Klingon Attack)

May: (8KF) Raid on Rukyverk (Klingon Attack)

June: (8KE) Attack on Battle Station K3 (Klingon Attack)

July: (8KG) Refueling Roulette (Klingon Attack)

August: (8KD) Delay in Sector (Klingon Attack)

If you missed one of these, make it up by 1 August and it will still count. (We're running a little behind processing the reports, but the Klingons seem to be winning two out of three.)

NEWS FOR COMMANDERS

Our Apologies for the Delay

This is supposed to be the June issue, and it was sent to the webmaster for uploading on 20 July. (The July issue will be along in about a week, the August issue after that.)

Communique #4 explains why that issue was late, and the delay in #4 of course delayed everything else.

THE BBS: KEYS TO COMMUNICATION

The BBS (www.starfleetgames.com/discus) can be confusing at first sight, as it has hundreds of topics, used daily by a thousand players. Registration is free, but we do require all participants to use their real names. (This not only improves the overall tone of civility, but makes sure you get credit for any suggestions you make.) When you register, you will see topics for each of our product lines. Feel free to venture into the broader universe as you get more comfortable with the system.

(8C1) THE FIRST BATTLE OF JUGGERNAUT BETA

Unaware of what kind of enemy they are facing, three Star Fleet ships and a Federation police cutter close in on what turns out to be *Juggernaut Beta*.

(8C1A) NUMBER OF PLAYERS

Two, the “Juggernaut” player (who controls the Juggernaut) and the “Star Fleet” (who is here to destroy it).

(8C1B) INITIAL SET UP

Lay out the six map panels three wide and two high, using the small size hexes. For convenience, call these A (upper left), B (upper center), C (upper right), D (lower left), E (lower center), and F (lower right). You can use the larger size hexes if you use more panels (three high by five wide).

The map will float in any direction.

Set up the Juggernaut in the center of the map (Panel B, hex 0715) facing in any direction.

Set up the Fast Cruiser *Eagle* (from Booster #4) in Panel D, hex 0115. Set up the New Light Cruiser *Kearsarge* (from Romulan Border) in Panel C, hex 1401. Set up the frigate *Auchintek* (from Klingon Border) in Panel A, hex 0101. Set up the Police Ship *Babek* (from Klingon Attack) in Panel F, hex 1415. All of the ships will face the Juggernaut.

If you wish, you can clutter up the map with the Armed Priority Transport *Cedar Falls* (from Romulan Border) in Panel B, hex 0701) and the Free Trader *Jerry James* (from Klingon Attack) in Panel E, hex 0915. These two ships will have a barely noticeable impact on the scenario other than giving the Juggernaut something else to destroy.

(8C1C) OBJECTIVE

Star Fleet Mission: The mission is to destroy the Juggernaut. Since these forces probably cannot do this (the scenario is seriously unbalanced) it will be considered a victory if every ship scores at least some damage on the Juggernaut and if at least one ship scores internal damage. (Every ship destroyed reduces the number of ships that scored internal damage by one, so if one ship is destroyed but two scored internal damage, it would still be a victory for Star Fleet.)

Juggernaut Mission: Destroy every one of the ships, or (failing that) force all ships not destroyed to disengage.

(8H4) SPECIAL RULES

Any Star Fleet ship which moves to a hex more than 25 hexes from the Juggernaut is considered to have disengaged. Such a ship is removed from the scenario immediately and takes no further part in the battle. There is no time limit.

(8H5) FORCE DYNAMICS

The balance of the scenario can be adjusted by giving each player a stronger or less effective force. If you use Squadron-Scale Ships against a Fleet Scale Juggernaut, the scenario is almost balanced. To give the Federation a greater chance, add a light cruiser in place of the *Jerry James* and a war destroyer in place of the *Cedar Falls*.

You could replace the Juggernaut with another monster, such as a Space Dragon or Planet Killer, or with a Dreadnought (perhaps a Klingon C8 or a Romulan Condor).

Place a convoy of several freighters 100 hexes in any direction from the Juggernaut. These will move away from the Juggernaut at their top speed, but every freighter must remain within four hexes of every other freighter. The Juggernaut victory conditions are changed to destroying every ship of this convoy. The possibilities are endless!

WHAT SHIPS DO YOU WANT?

Here is your chance to get what you want. Whether you are a veteran player of *Star Fleet Battles* and familiar with the thousands of starships in that game system, or a new player of *Federation Commander* and just have a vague feeling that some ship of some kind is missing from your fleet, tell us what you want and we'll consider adding it via *Communique* or in a future expansion.

This issue includes a larger version of the Federation Dreadnought. A player asked us to include this so he could have more room to mark damage.

Players asked us to include the Klingon F5W War Destroyer and it is in this very issue.

Players have asked us to include the original Franz Joseph dreadnought in a future issue of *Communique* and we'll get that done as soon as we can. We may also try doing a tug (but leaving out the “drop the pod” rules and just using it as a big cargo ship).

Now that *Romulan Border* has made the decision on Fleet Scale plasma torpedoes, we plan to do new Fleet Scale versions of the King Eagle, K7R, and ISC CA from Booster Zero and put them in *Communique*. The first of these (the King Eagle) is in this issue. (It was already done for the future *Romulan Attack* module which is currently in final playtest.)

Captain's Log #34 includes Fleet Scale War Cruisers for the Hydrans, Lyrans, WYNS, & ISC published in *Booster Zero*. We can do ships for these empires.

Some recently requested ships include Q-ships, the Orion Battle Raider, and the Romulan Vulture. We'll see about getting those done in future issues.

FEDERATION COMMANDER: 2007

We are reviewing the product line, player requests, and what we think would make good products, and have “lightly pencilled in” the following modules for next year:

THOLIAN ATTACK would be a typical attack module with two map panels, 16 ships, and the rules for the web, web caster, and web fist. The 16 ships would include eight for the Tholians (Dreadnought, Heavy Cruiser, War cruiser, and the five Neo-Tholian ships — NDN, NCA, NCL, NDD, NFF), a new monster, perhaps a new base of some sort, a couple for the Klingons (probably including the F5W), and a couple of Federation ships.

BATTLESHIPS would include larger 8.5x11 ship cards for seven huge (movement cost 2) battleships and a squadron scale starbase.

For a third module, one choice is *DISTANT KINGDOMS* (Hydrans, Lyrans, and WYNS) but we may want to hold that for 2008 and pair it with *KINGDOMS AT-TACK* and maybe *ANCIENT ENEMIES*. Another choice is the Orion Pirates module. The *WAR AND PEACE* module (which might be a good place to include the Interstellar Concordium) is another choice.

REVISED SHIP CARD

ROMULAN KING EAGLE CRUISER

FLEET SCALE

COUNTER

POINT VALUE: 75

DAMAGE CONTROL: 2

POWER TRACK



22
21
20
19
18
17
16
15
14
13
12
11
10
9
8
7
6
5
4
3
2
1
0

WEAPONS USED

A

1 2 3

The Weapons Used track records that a weapon was fired during the current turn.

PROBES

5 empty slots

MARINES

5 empty slots

FRAME DAMAGE

3 empty slots

RIS _____
Name

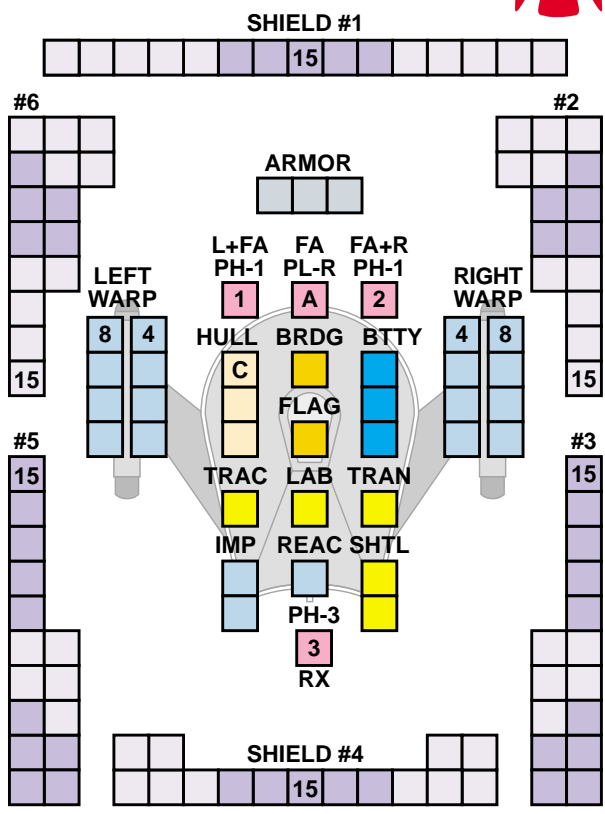

CLOAK COST = 1+1/2

TURN MODE D MOVE COST 1/2

BASE SPEED 8 TURN MODE 2 SPEED COST 4

BASE SPEED 16 TURN MODE 4 SPEED COST 8

BASE SPEED 24 TURN MODE 5 SPEED COST 12

ACCELERATION COST 1/2

DECELERATION COST 1/2

HIGH ENERGY TURN COST 2+1/2

EVASIVE MANEUVER COST 3

PLASMA A

5x5 grid

SHUTTLES

2 shuttle icons

PLASMA ARMING

A 5 empty slots G S R

The publisher of this game grants permission to players to make a reasonable number of photocopies of this page (up to 25 per month) for the personal use of the player. Reproduction for sale is not authorized.

NEW SHIP CARD

KLINGON F5W DESTROYER

FLEET SCALE

COUNTER
 POINT VALUE: 56
 DAMAGE CONTROL: 1



POWER TRACK

16
15
14
13
12
11
10
9
8
7
6
5
4
3
2
1
0

PROBES

--	--	--	--	--

MARINES

--	--	--	--	--	--	--

#6

FRAME DAMAGE

--	--

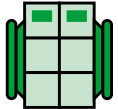

WEAPONS USED

A	1	2	3	4	Z
---	---	---	---	---	---

10

IKV Name _____

SHIELD #1

			13			
--	--	--	----	--	--	--

#2

TURN MODE A MOVE COST 1/4
BASE SPEED 8 TURN MODE 1 SPEED COST 2
BASE SPEED 16 TURN MODE 2 SPEED COST 4
BASE SPEED 24 TURN MODE 4 SPEED COST 6
ACCELERATION COST 1/4
DECELERATION COST 1/4
HIGH ENERGY TURN COST 1+1/4
EVASIVE MANEUVER COST 1+1/2

#5

8					
---	--	--	--	--	--

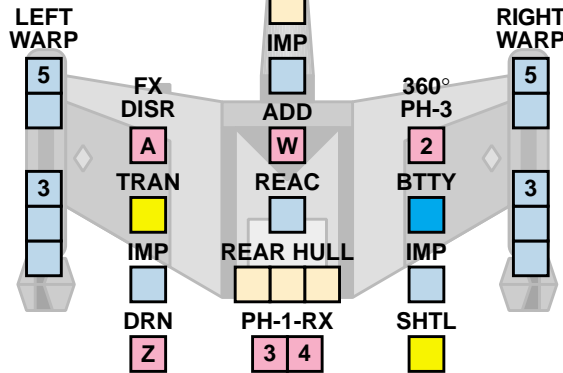

#3

8			
---	--	--	--

DRONE RACK

--	--

ANTI-DRONES IMP USED

1	2	3	4
5	6	7	8

DRONES

1				
2				

DRONES

3				
4				

ANTI-DRONE W

--	--	--	--	--

SHIELD #4

	8	
--	---	--

C6

FEDERATION COMMANDER: COMMUNIQUE #6
 PLAYTEST FLEET SCALE SHIP CARD
 Copyright © 2006 Amarillo Design Bureau, Inc.

FRACTIONAL POWER

0 1/4 1/2 3/4

The publisher of this game grants permission to players to make a reasonable number of photocopies of this page (up to 25 per month) for the personal use of the player. Reproduction for sale is not authorized.

NEW SHIP CARD

KLINGON F5W DESTROYER

SQUADRON SCALE

COUNTER
 POINT VALUE: 110
 DAMAGE CONTROL: 2



POWER TRACK
 28
 27
 26

PROBES

--	--	--	--	--

MARINES

--	--	--	--	--	--	--	--

FRAME DAMAGE

--	--	--	--

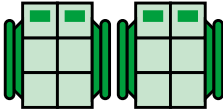

WEAPONS USED

A	B	1	2	3	4
5	6	7	Y	Z	

TURN MODE A
 MOVE COST 1/2

BASE SPEED 8
 TURN MODE 1
 SPEED COST 4

BASE SPEED 16
 TURN MODE 2
 SPEED COST 8

BASE SPEED 24
 TURN MODE 4
 SPEED COST 12

ACCELERATION
 COST 1/2

DECELERATION
 COST 1/2

HIGH ENERGY
 TURN COST 2+1/2

EVASIVE MANEUVER
 COST 3

ANTI-DRONE W

--	--	--	--	--

IKV _____
 Name

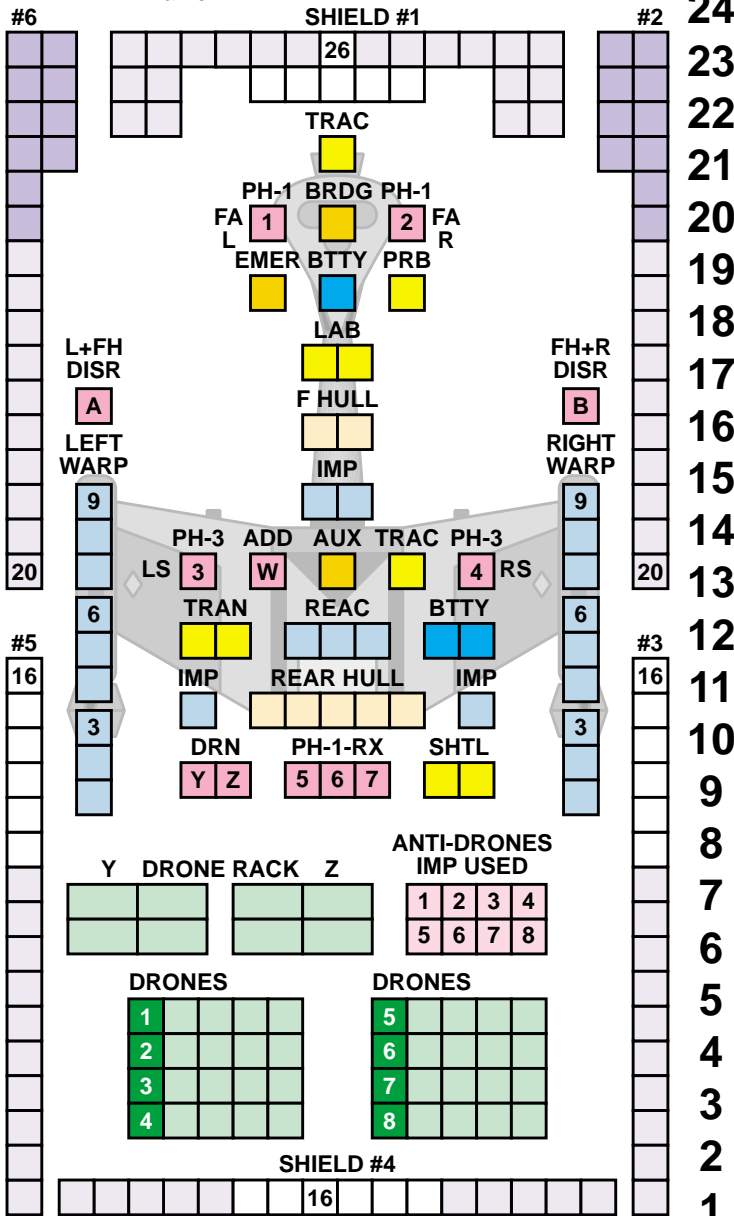

The publisher of this game grants permission to players to make a reasonable number of photocopies of this page (up to 25 per month) for the personal use of the player. Reproduction for sale is not authorized.



FEDERATION COMMANDER: COMMUNIQUE
 PLAYTEST SQUADRON SCALE SHIP CARD
 Copyright © 2006 Amarillo Design Bureau, Inc.

FRACTIONAL POWER 0
 0 1/2

