

REVISED SHIP CARD

WYN AUXILIARY CRUISER FLEET SCALE

WDS _____
Name

MARINES

2

FRAME
DAMAGE

1

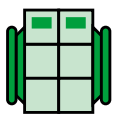

This ship has
no probe
launcher.

TURN MODE C MOVE COST 1/8	#6
BASE SPEED 8 TURN MODE 2 SPEED COST 1	#5
BASE SPEED 16 TURN MODE 3 SPEED COST 2	#4
BASE SPEED 24 TURN MODE 5 SPEED COST 3	#3
ACCELERATION COST 1/8	#2
DECELERATION COST 1/8	#1
HIGH ENERGY TURN COST 5/8	0
EVASIVE MANEUVER COST 3/4	0

COUNTER **AXC**
POINT VALUE: 33
DAMAGE CONTROL: 2

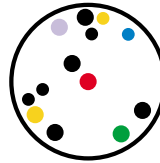

POWER
TRACK

12

11

10

9

8

7

6

5

4

3

2

1

0

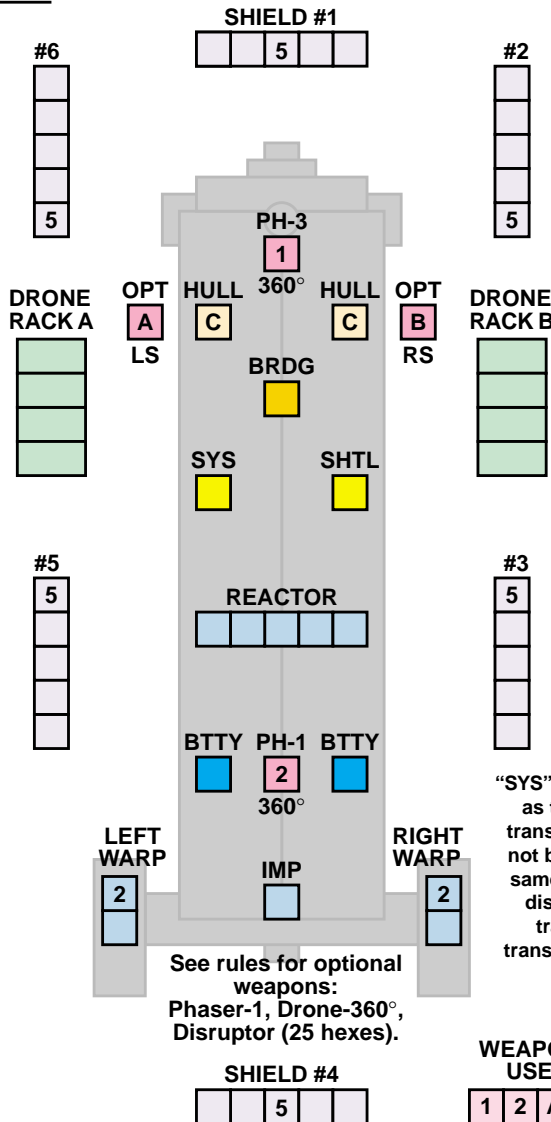

See rules for optional
weapons:
Phaser-1, Drone-360°,
Disruptor (25 hexes).

"SYS" can be used
as tractor or
transporter, but
not both on the
same turn. It is
disabled on
tractor or
transporter hits.

WEAPONS
USED
1 2 A B

FRACTIONAL POWER

142 0 1/8 1/4 3/8 1/2 5/8 3/4 7/8

There was nothing "wrong" with the original Ship Card for this vessel. Indeed, we just published it in *Hydran Attack* a few days ago, but it is the most common WYN ship and we thought it should be available as a PDF.

The publisher of this game grants permission to players to make a reasonable number of photocopies of this page (up to 25 per month) for the personal use of the player. Reproduction for sale is **not authorized.**

REVISED SHIP CARD

WYN AUXILIARY CRUISER SQUADRON SCALE

COUNTER **AXC**
POINT VALUE: 65
DAMAGE CONTROL: 4

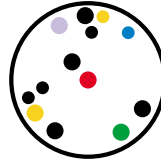

POWER TRACK

- 24
- 23
- 22
- 21
- 20
- 19
- 18
- 17
- 16
- 15
- 14
- 13
- 12
- 11
- 10
- 9
- 8
- 7
- 6
- 5
- 4
- 3
- 2
- 1
- 0

WDS _____
Name

MARINES
4

FRAME DAMAGE
2

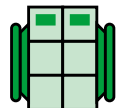

This ship has no probe launcher.

TURN MODE C MOVE COST 1/4
BASE SPEED 8 TURN MODE 2 SPEED COST 2
BASE SPEED 16 TURN MODE 3 SPEED COST 4
BASE SPEED 24 TURN MODE 5 SPEED COST 6
ACCELERATION COST 1/4
DECELERATION COST 1/4
HIGH ENERGY TURN COST 1+1/4
EVASIVE MANEUVER COST 1+1/2

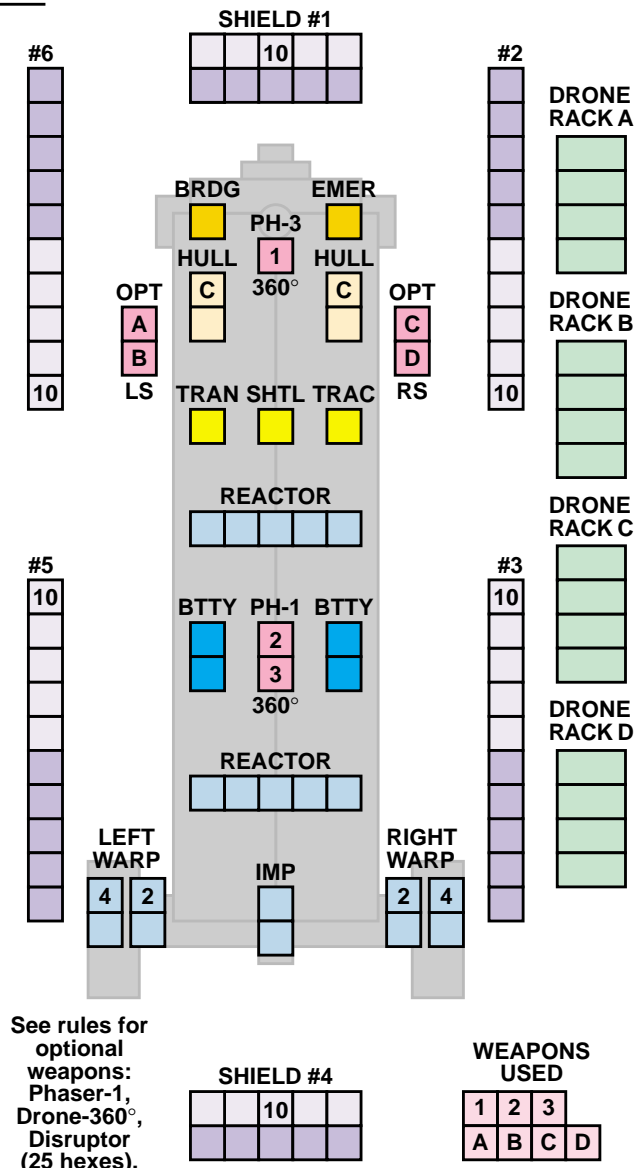

See rules for optional weapons: Phaser-1, Drone-360°, Disruptor (25 hexes).

FRACTIONAL POWER
0 1/4 1/2 3/4

There was nothing "wrong" with the original Ship Card for this vessel. Indeed, we just published it in *Hydran Attack* a few days ago, but it is the most common WYN ship and we thought it should be available as a PDF.

The publisher of this game grants permission to players to make a reasonable number of photocopies of this page (up to 25 per month) for the personal use of the player. Reproduction for sale is **not authorized.**